

A2 - HEADER TANK WITH THREADED CONNECTIONS DN 5" 6" 8" 10"

TF SERIES

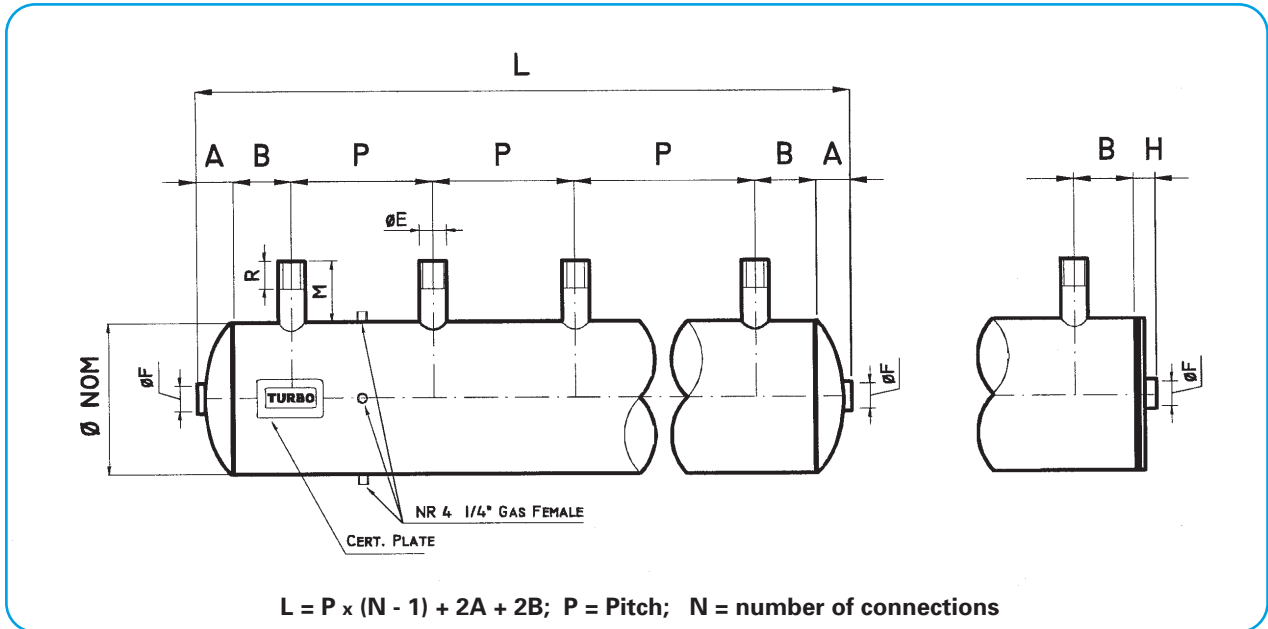

Designer should specify the valve pitch (P), the number of valves mounted on the tank (N) and the integral or remote solenoid pilot.

Minimum distance between the last valve center line and tube end is required.

When longer dimensions are required add "s" to the ordering code and specify the requested dimension (i.e. B =)

See "How to order" page to complete the correct tank code.

Code: TF Ø N ** P ***

}

B
F

** specify number of threaded connections
 *** specify valve pitch

Inner Ø (inches)	Outer Ø (mm)	Ø E BSP	A	B min	Ø F BSP	H	M	Z ±	R
5	140	3/4"	50	40	1"	15	85	120	45
5	140	1"	50	40	1"	15	85	120	45
6	168,3	3/4"	50	40	1"	15	85	120	45
6	168,3	1"	50	40	1"	15	85	120	45
6	168,3	1 1/2"	50	40	1"	15	85	136	45
8	219,1	1"	70	40	1 1/2"	18	85	120	45
8	219,1	1 1/2"	70	40	1 1/2"	18	85	136	45
8	219,1	2"	70	65	1 1/2"	18	85	150	45
10	273	1 1/2"	90	40	1 1/2"	18	85	136	45
10	273	2"	90	65	1 1/2"	18	85	150	45
10	273	2 1/2"	90	65	1 1/2"	18	85	150	45

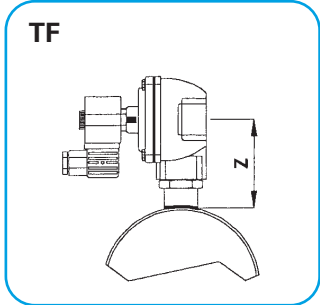

TURBO

TURBO SRL
Via San Carlo 99
20021 Cassino Mediano
(Milano) Italy
Phone +39 362 574024
Fax +39 362 574030

ACCORDING TO 87/404 90/488

TEMP C°

Max pressure Volume lt

Serial No

CE AP030/99 ID 0066

See page at end of this section for mounting brackets.

● Standard painting RAL5012